



ELECTRICAL TRANSDUCER

CE-T Series

Introduction

Shenzhen Sensor Electronic Technology Co., Ltd specializes in researching, developing and manufacturing of electrical transducers. Our advanced test instrumentation and engineering capabilities provide a most favorable environment for transducer manufacturing. Our quality and inspection departments are among the most advanced in China. The output of our production facility is over one hundred thousand units annually.

The most important aspect of our production is “Quality”. Our products are manufactured and certified to the 2000 quality standards of ISO 9001. The transducers have been approved UL, CUL, CMC, CE and RoHS. The US Council of International Quality Authentication has recommended us for our high quality standards. Shenzhen Sensor Electronic Technology Co., Ltd. is the only manufacturer of electrical transducers in China to have obtained all of these certifications.

Our corporate psychology of Research & Development and efficient manufacturing has made us predominant worldwide in the electrical transducer market. Our diverse lines of products are used for signal isolation and modulation, analog and digital communication in standard and smart instrumentation networks. The complete line consists of nearly one hundred sub-categories with numerous standard and custom versions available in each of these sub-categories.

The CE Series of products is used for monitoring electrical parameters of current, voltage, power and frequency. Technologies such as electrical induction, Hall Effect and magnetic modulation are used in our product line for monitoring alternating and direct current systems.

The CE Series of products consists of three main categories.

CE-T series for providing analog output signal such as 0-5 Vdc and 4-20mA

CE-A series for providing digital output signal such as RS485/232

CE-H series for hall effect transducer.

The principal characteristics of our products are:

Micro miniaturization, utilizing surface Mounting technology.

Modularization, each function provided by a unique PCB.

High reliability, all components are high-reliable, precision grade.

Low power consumption, high efficiency regulators and dc-dc power supplies.

High dielectrics withstand voltage, designed into each product.

Single sided input power requirement, for easy installation.

High quality, reliability and low price have made our transducers most efficient for application in the areas of communication, electric power, automotive energy production, and industrial control. We have received high praise from thousands of customers. We currently provide our products to numerous countries.

OUR MANAGEMENT CONCEPT: Green is the symbol of life;
CE is a pledge of reliability.

OUR MISSION STATEMENT: Research, develop and manufacture a complete line of electrical monitoring products. Quality, Reliability and Customer satisfaction are our utmost concern.

CONTENTS

Chapter 1 Selection Guide

1.1	Part Number	1
1.2	Main Series List	2

Chapter 2 Product Overview

2.1	Output Function Codes	3
2.2	Typical Operating Specifications	4
2.3	Input / Output Graphs	4

Chapter 3 Details of the Electrical Transducer

3.1	Current Transducer	5
3.2	Voltage Transducer	11
3.3	Frequency Transducer	17
3.4	Power Transducer:	19
3.5	1-element AC/DC Offside Alarm Transducer	21
3.6	Standard Signal Isolator	22
3.7	Self Power Transducer	24
3.8	Split Core Self Power AC Current Transducer	29
3.9	Split Core DC Current Transducer	30
3.10	Split Core AC Current Transducer	31
3.11	Power Supply	32

Chapter 4 Case style and Mounting Diagram

4.1	Case Styles and Outline Dimension	33
4.2	Mounting Dimensions (mm)	34

Chapter 5 Notes for Ordering

5.1	Ordering Instructions	35
5.2	Installation Notes	35
5.3	Warranty service	35

Chapter 1 Part Number Selection Guide

1.1 Part Number

Please follow the instruction below to fix the full part number, one square one code, from left to right.

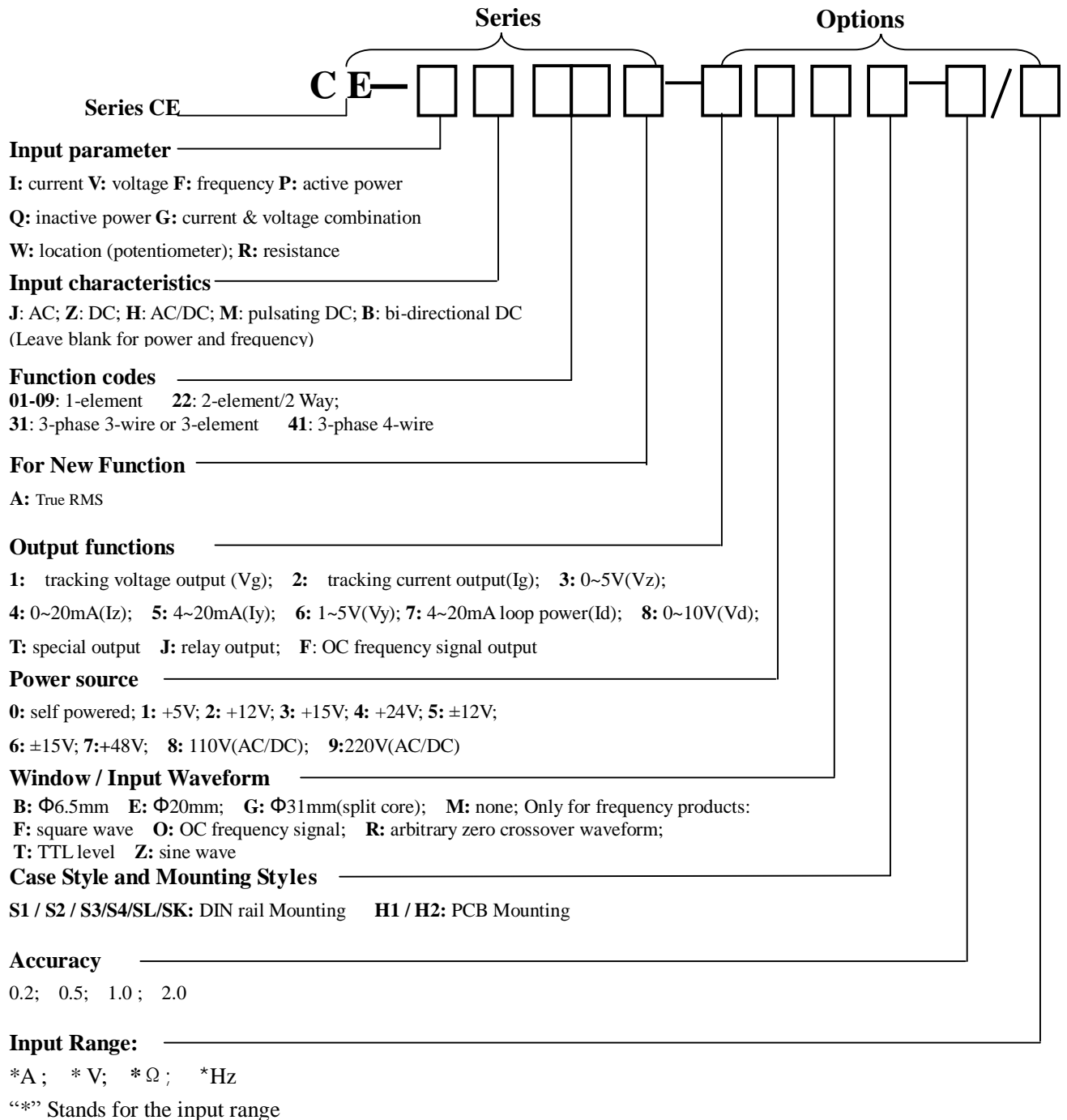

Typical Example

CE-IJ 03-32BS2-0.5/0-5A: 1 element AC Current Transducer, Output: 0-5V, Power Supply: +12V, Window: Φ6.5mm, Case Style: S2, Accuracy: 0.5, Input Range: 0 – 5 A

1.2 Main Series List

MAIN SERIES LIST FOR CE-T ANALOG ELECTRICAL PARAMETER TRANSDUCER				
FUNCTION TYPE			SERIES	Page
Current	AC	1 element	CE-IJ03	5
			CE-IJ03A (RMS)	
		3 elements	CE-IJ31	7
	CE-IJ31A (RMS)			
	DC	1 element	CE-IZ01	9
			CE-IZ02	
CE-IZ04**				
CE-IZ06				
Voltage	AC	1 phase	CE-VJ03	11
			CE-VJ03A (RMS)	
		3-phase 3-wire	CE-VJ31	13
			CE-VJ31A (RMS)	
	3-phase 4-wire	CE-VJ41	15	
		CE-VJ41A (RMS)		
	DC	1-phase	CE-VZ01	15
			CE-VZ02	
Power	AC	1 element	CE-P02	19
			CE-Q02	
		3-phase 3-wire	CE-P31	
			CE-Q31	
		3-phase 4-wire	CE-P41	
			CE-Q41	
Frequency	AC	1-element	CE-F01	17
			CE-F03	
Split Core	AC	1-element	CE-IJ03-**GS4	29
	DC	1-element	CE-IZ04-**GS4	30
Self Power Current	AC	1-element	CE-IJ03-*0	24
		3 elements	CE-IJ31-*0	26
Self Power Voltage		1-element	CE-VJ03-*0	27
		3-phase 4-wire	CE-VJ41-*0	28
Power supply			CE-WYS	32

Chapter 2 Product Overview

2.1 Output Function Codes

Code	Symbol	Definition	Applications
1	Vg	Tracking Voltage Output	0-5V (RMS), suitable for AC or peak value sampling system, quick response, and high precision.
2	Ig	Tracking Current Output	AC tracking current output, suitable for AC or peak value sampling system, high precision, and quick response.
3	Vz	DC Voltage Output	0-5V DC, can be connected direct to A/D converter, digit panel, indicator, PLC
4	Iz	DC Current Output	0-20mA DC, suitable for long distance signal transmission, resistance to interference.
5	Iy	DC Current Output	4-20mA DC, suitable for long distance signal transmission, resistance to interference.
6	Vy	DC Voltage Output	1-5V DC, can be connected direct to A/D converter, digit panel, indicator,
7	Id	2-wire DC Current	4-20mA DC, 2-wire, loop powered connection, resistance to interference.
8	Vd	DC Voltage Output	0-10V DC, can be connected direct to digit panel, indicator etc. (auxiliary Power supply $\geq 15V$).
J	J	Relay contact	Apply to offside alarm for AC/DC current and voltage
F	F	OC frequency signal output	0~5k, 0~10k Hz frequency signal, photoelectric isolation OC output
T	T	Special Output	Reserved for special output configurations.

2.2 Typical Operating Specifications

Item	Test Condition	Data	
		Accuracy 0.2	Accuracy 0.5
Thermal Drift	+12V, 25°C	≤200ppm/°C	≤500ppm/°C
Output Ripple	+12V, 25°C	10mV	15mV
Output Load	+12V, 25°C Vz (3) output	≥2KΩ	
	+12V, 25°C Iz (4) and Iy (5) output	≤250Ω	
Operating Temperature	+12V	0~50 °C	
Humidity	+12V	≤95% (no dew)	
Isolation With standing Voltage	0.5mA, 1 min.	≤2500 V dc	
Power Consumption (mW)	+24V	See specifications	

2.3 Input / Output Graphs.

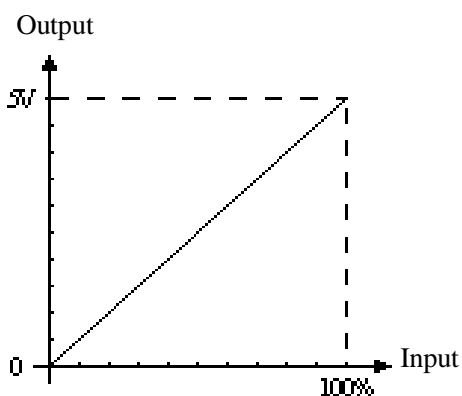

Uni-direction input vs 0-5V output

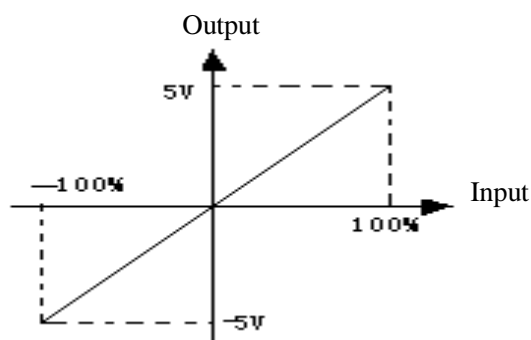

Bi-direction input vs bi-directional output

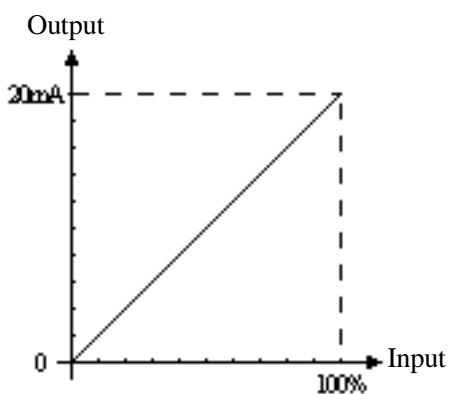

Uni-direction input vs 0-20 mA output

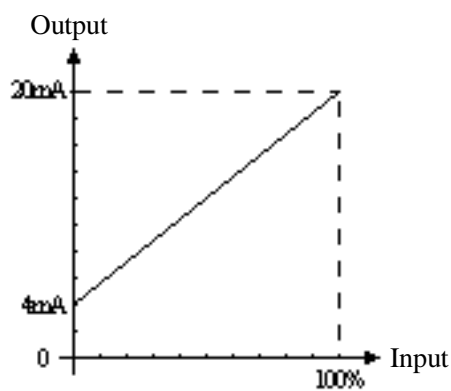

Uni-direction input vs 4~20 mA output

Chapter 3 Details of the Electrical Transducer

3.1 Current Transducer

3.1.1 1-element AC Current Transducer

Specifications:

Series	Operating Principle	Isolation Voltage	Response Time	Overload Capacity	Power Consumption (mW)		Mounting
					Vz, Vd, Vg, Iz Output	Iy Output	
CE-IJ03 CE-IJ03A	Electro-Magnetic	2500 VDC	≤250mS	20 times or <5/sec at 500A	360	450	PCB Din Rail Screw

Part Numbers:

Series	Output	Power Supply	Window (mm)	Case Style	Accuracy %	Rated Input
CE-IJ03	3:0~5V DC (Vz)	2:12V	B: Φ6.5	H1	0.5	0.5A, 1A, 5A, 10A, 15A, 25A
CE-IJ03 CE-IJ03A	1:0~5V RMS (Vg)*	2:12V	M: none	S2		0.5A, 1A, 5A
	3:0~5V DC (Vz)	3:15V	B: Φ6.5			5A, 10A, 15A, 25A
	4:0~20mA (Iz)**	4:24V	E---Φ20	S3		30A, 50A, 75A, 100A, 120A, 150A, 200A, 250A, 300A
	5:4~20mA (Iy)**	5:±12V				
	6:1~5Vdc (Vy)*	6:±15V				
7:4~20mA (Id) ***	8:110V	SK	S3	10A, 20A		
8:0~10V DC (Vd)*	9:220V					

* Output types Vg, Vy, Vd, Id are not available in series CE-IJ03A.

** Loop resistance from 0 to 250Ω. Contact factory for loop resistance above 250 Ω

*** Select 24V Power supply for output of 4~20mA Id;

Part Number Example: CE-IJ03-54ES3-O.5/0~50A

Description: 1-element AC Current Transducer, average RMS, Output: 4~20mA, Power supply: +24V DC, Aperture: Φ20mm, Case style: S3, Accuracy: 0.5%, Input: 0~50A AC.

Connections Diagrams (See Chapter4 for mounting dimensions)

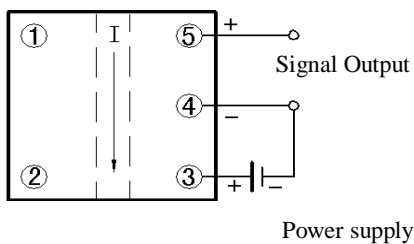

Fig. 3.1.1 for CE-IJ03 Case-H1

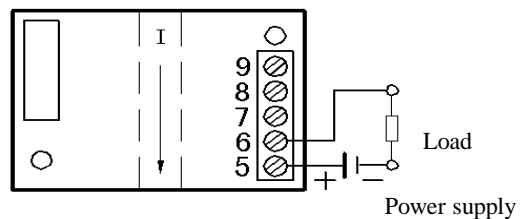

Fig. 3.1.2 for CE-IJ03 with loop power Case-S

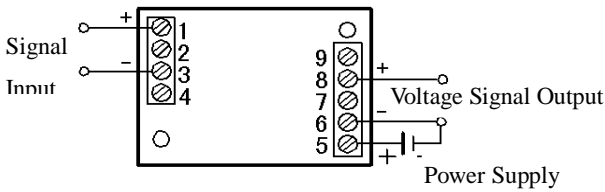

Fig. 3.1.3 for CE-IJ03, CE-IJ03A
Terminal Input, Voltage Output, Case-S

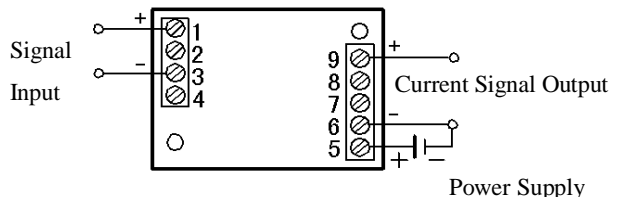

Fig. 3.1.4 for CE-IJ03, CE-IJ03A
Terminal Input, Current Output, Case-S,

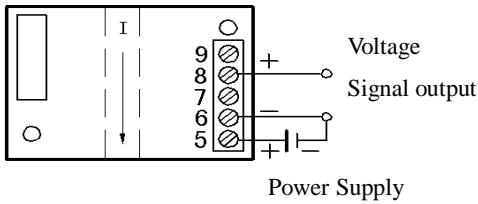

Fig. 3.1.5 for CE-IJ03, CE-IJ03A
Window Input, Voltage Output, Case style S

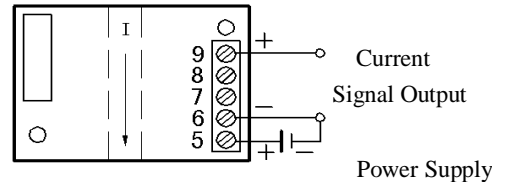

Fig. 3.1.6 for CE-IJ03, CE-IJ03A
Window Input, Current Output, Case style S

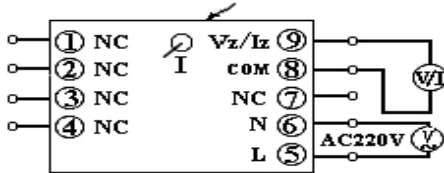

Fig. 3.1.7 for CE-IJ03, Power Supply 220V/110V
Window Input, Case style S

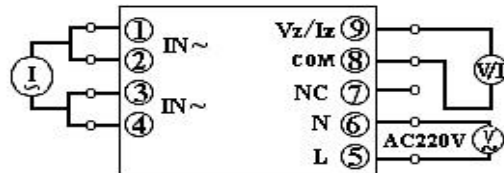

Fig. 3.1.8 for CE-IJ03, Power Supply 220V/110V
terminal Input, Current Output, Case style S

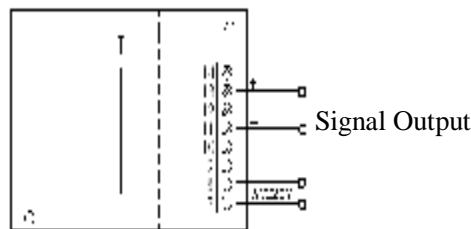

Fig. 3.1.9 for CE-IJ03, Power supply 220/110V
Window Input, Case style SK

Typical Application:

1. Multi-point current sensing and control panels
2. Monitor lighting elements
3. Monitor heating elements
4. Remote current sensing
5. Monitor motor faults

Notice:

1. The size of window must be fit for the conducting wire to pass through. When the rated current $\leq 5A$, please use terminal input.
2. All connections of the positive and negative polarities must be correct. The output signal and the power supply must be grounded in common at terminal 6.
3. If other meter is used to read the value of the output, please make sure its accuracy is higher.

3.1.2 3-elements AC Current Transducer

Specifications:

Series	Operating Principle	Isolation Voltage	Response Time	Overload Capacity	Power Consumption (mW)		Mounting
					Vz,Vd,Vg, Iz Output	Iy Output	
CE-IJ31 CE-IJ31A	Electro-magnetic	2500VDC	≤250mS	20 times or <5/sec at 500A	400	600	Din Rail/ Screw

Part Numbers:

Series	Output	Power Supply	Window (mm)	Case Style	Accuracy %	Rated Input
CE-IJ31A CE-IJ31	1: 0~5V RMS (Vg)* 3: 0~5V DC (Vz) 4: 0~20 mA (Iz)* 5: 4~20 mA (Iy)** 8: 0~10V DC (Vd)	2: 12V 3: 15V 4: 24V	B---Φ6.5	S3	0.5	1A, 2A, 5A, 10A, 15A, 25A
CE-IJ31	3: 0~5V DC (Vz) 4: 0~20 mA (Iz) 5: 4~20 mA (Iy)** 6: 1~5V (Vy) 8: 0~10V DC (Vd)	8: 110V 9: 220V		SK SL		1A, 2A, 5A, 10A, 15A, 20A

*Tracking output (Vg,Iz,Vd) type not available in series CE-IJ31A

** Loop resistance from 0 to 250Ω. Contact factory for loop resistance above 250 Ω

Part Number Example: CE-IJ31-32BS3-0.5/0~5A

Description: 3 elements AC Current Transducer, average RMS, Output: 0-5Vdc, Power supply: +12Vdc, Aperture: Φ6.5mm, Case style: S3, Accuracy: 0.5 %, Input: 0-5A AC.

Connections Diagram (See Chapter4 for mounting dimensions)

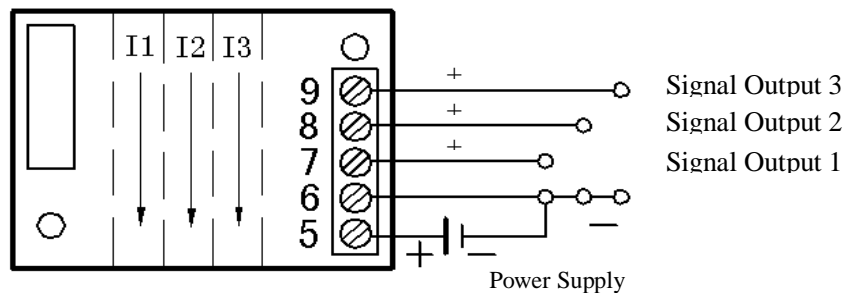

Fig. 3.1.10 CE-IJ31, CE-IJ31A Case style S

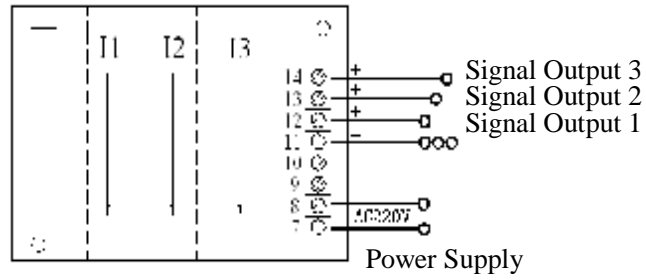

Fig. 3.1.11 CE-IJ31, CE-IJ31A Case style SK

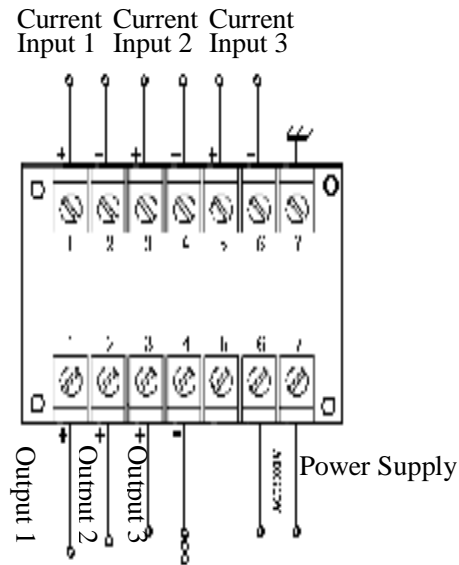

Fig. 3.1.12 CE-IJ31 Case style SL
Don't use the terminal named NC.

Typical Application:

1. Phase fired controlled heaters
2. Quickly varying motor loads
3. Chopped wave form drivers
4. Harmonic currents

Notice:

1. The output signal and the power supply must be grounded in common at terminal 6.
2. For application above 25 Amp, It is suggested to use an external current transformer. Connect the secondary output of the current transformer to the input of the transducers.
3. There is no polarity requirement for the input signal connection.

3.1.3 1-element DC Current Transducer

Specifications:

Series	Operating Principle	Isolation Voltage	Response Time	Overload Capacity	Power Consumption (mW)		Mounting
					Vz, Vd, Vg, Iz Output	Iy Output	
CE-IZ01	Photoelectric Isolation/ Treble isolation*	2500VDC	≤10mS	2 Times 10/sec	180	300	PCB /Din Rail / Screw
CE-IZ02	Modulation Isolation		≤15mS		200	300	
CE-IZ04	Hall Effect Isolation		≤100mS	20 times or <5/sec at 500A	350	550	
CE-IZ06	Modulation Isolation		≤100mS		600	700	

I Treble Isolation: the input, output and power supply is isolated from each other.

Part Numbers:

Series	Output	Power Supply	Window (mm)	Case Style	Accuracy %	Rated Input
CE-IZ01	3: 0~5VDC(Vz)	2: 12V 3: 15V 4: 24V	M: none No window	S1	0.2	20mA, 50mA, 100mA, 200mA,
	4: 0~20mA(Iz)	8: 110V 9: 220V		S3		500mA, 1A, 2A, 5A
	5: 4~20mA(Iy)*					
CE-IZ02	6: 1~5VDC(Vy)	2: 12V	E: Φ20	H2 S1	1.0	20mA, 50mA, 100mA, 200mA,
CE-IZ04	8: 0~10VDC(Vd)	3: 15V 4: 24V		S2		500mA, 1A, 2A, 5A
		5: ±12V				
CE-IZ06	F: Frequency signal	6: ±15V		S3		30A, 50A, 80A, 100A, 120A,150A, 200A,300A 1A, 2A, 5A,10A, 20A

* Loop resistance from 0 to 250Ω. Contact factory for loop resistance above 250 Ω

Part Number Example: CE-IZ01-32MS2-0.2/0-1A

Description: 1- Element DC Current Transducer, average RMS, Output: 0~5V DC, Power supply: +12V DC, No window (Terminal input), Accuracy: 0.2%, Case style: S2, Input: 0-1A.

Connections Diagram (see Chapter 4 for mounting dimensions)

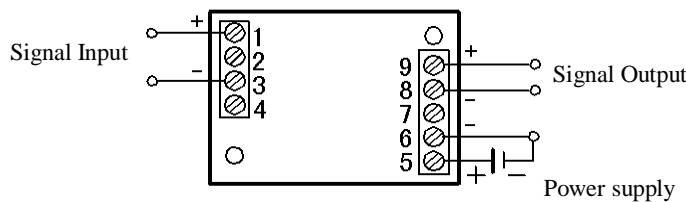

Fig. 3.1.13 CE-IZ01 Case style S1

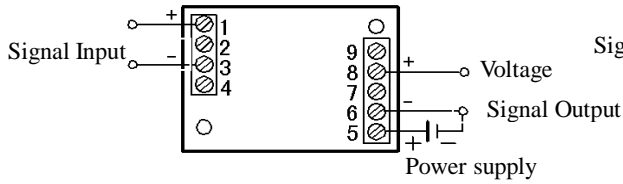

Fig. 3.1.14 CE-IZ02

Voltage Output, Case style S2

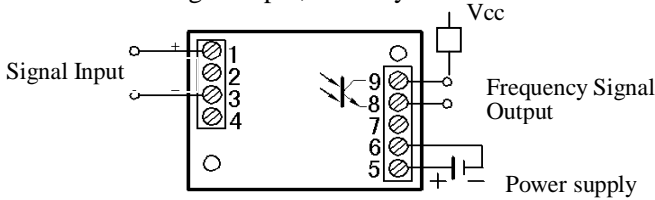

Fig 3.1.16 CE-IZ02

Frequency Output, Case style S2

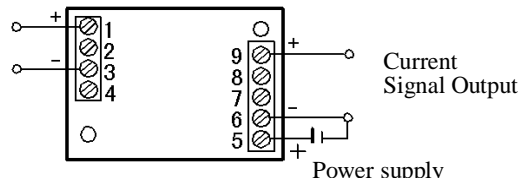

Fig. 3.1.15 CE-IZ02

Current Output, Case style S2

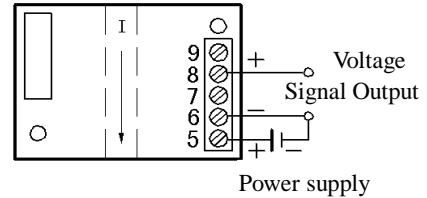

Fig. 3.1.17 CE-IZ04, CE-IZ06

Voltage Output, Case style S2

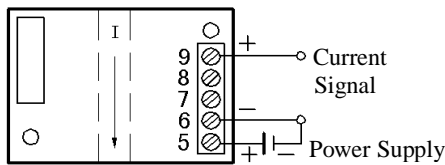

Fig. 3.1.18 CE-IZ04, CE-IZ06

Window Input, Current Output, Case style S3

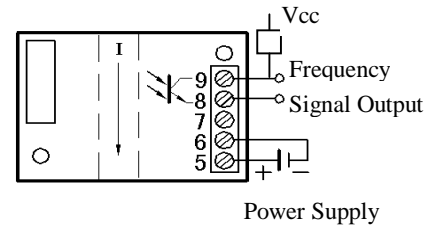

Fig. 3.1.19 CE-IZ04, CE-IZ06

Frequency Output, Case style S

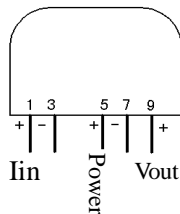

Fig. 3.1.20 CE-IZ02

Voltage Output, Case style H2

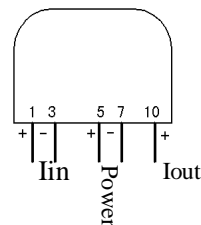

Fig. 3.1.21 CE-IZ02

Current Output, Case style H2

Typical Applications:

1. Power supply management
2. DC motor drives
3. Battery chargers and systems
4. Mobile applications

Notice:

1. If the input signal is bi-directional DC or pulse DC, please indicate in your order.
2. In case a current (>1A) is input through the terminals, it is advisable to connect terminals 1&2 in parallel, and terminals 3&4 in parallel respectively in order to reduce the input resistance at the terminals.
3. CE-IZ01 works on Treble isolation Principle, the output signal and the Power supply may not be grounded in common. (While that of other part numbers must be grounded in common)

3.2 Voltage Transducer

3.2.1 1-phase AC Voltage Transducer

Specifications:

Series	Operating Principle	Isolation Voltage	Response Time	Overload Capacity	Power Consumption (mW)		Mounting
					Vz,Vd, Vg,,Iz Output	Iy Output	
CE-VJ03 CE-VJ03A	Electromagnetic Isolation	2500 VDC	2500mS	2 Times 10/sec	50(H1) 180(S,H4)	250	PCB/ Din rail/Screw

Part Numbers:

Series	Output	Power Supply	Window(mm)	Case Style	Accuracy %	Rated Input	
CE-VJ03	3:0~5VDC(Vz)	2:12V	M: none	H1****	0.5	10V, 50V, 100V, 110V, 220V,250V, 380V,400V, 500V,1000V	
CE-VJ03 CE-VJ03A	1:0~5VRMS(Vg)*	2:12V		S2	0.2		
	3:0~5VDC(Vz)	3:15V					
	4:0~20mA(Iz)	4:24V		S3			
	5:4~20mA(Iy)**	5:±12V					
	6:1~5VDC(Vy)*	6:±15V		S3			0.5
	7:4~20mA(Id)***	8:110V					
8: 0~10V DC (Vd)*	9: 220V						

* Output types (Vg,Vy,Vd,) and accuracy 0.2 are not available in series CE-IJ03A.

** Loop resistance from 0 to 250Ω. Contact factory for loop resistance above 250 Ω

*** Select 24V Power supply for output of 4~20mA Id;

**** This case style needs an extra voltage divider

Part Number Example: CE-VJ03-52M52-0.2/0~250V

Description: 1-phase AC Voltage Transducer, Output: 4~20mA, Power supply: +12V, Without Window (terminal input), Accuracy: 0.2, Case style: S2 Input: 0~250V.

Connections Diagram (see Chapter 4 for mounting dimensions)

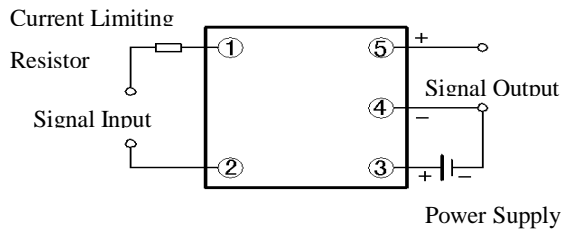

Fig. 3.2.1 CE-VJ03
Case style H1

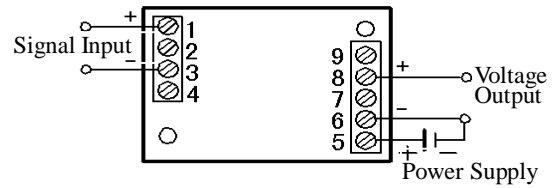

Fig. 3.2.2 CE-VJ03, CE-VJ03A
Voltage Output, Case style S

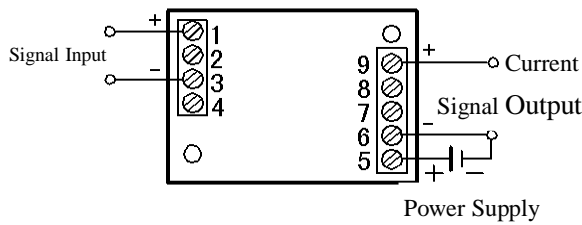

Fig. 3.2.3 CE-VJ03, CE-VJ03A
Current Output, Case style S

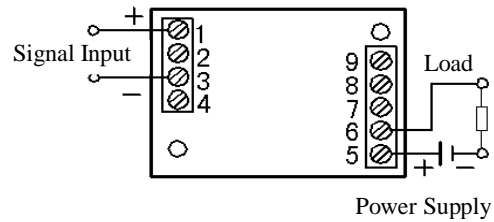

Fig. 3.2.4 CE-VJ03
Loop power, Case style S

Typical Application:

1. Monitor for over/under voltage
2. Power monitoring
3. Multi-point instrumentation needs
4. Sense phase loss

Notice:

1. Selection of output signal: Please select Power supply >15V when you need 0~10V output.
2. The H1 type must be used with corresponding current limiting resistor. The current limiting resistance should not be near the output terminal (to avoid larger voltage drop).
3. The output signal and the Power supply must be grounded in common. Please keep right polarity connection, don't in error set.

3.2.2 3-phase AC Voltage Transducer

Specifications:

Series	Operating Principle	Isolation Voltage	Response Time	Overload Capacity	Power Consumption (mW)		Mounting
					Vz, Vd, Vg, Iz Output	Iy Output	
CE-VJ31 CE-VJ31A	Electromagnetic Isolation	2500 V DC	≤250mS	2 Times 10/sec	400	500	Screw/ Din rail
CE-VJ41 CE-VJ41A							

Part Numbers:

Series	Output	Power Supply	Window (mm)	Case Style	Accuracy %	Rated Input
CE-VJ31 CE-VJ31A CE-VJ41 CE-VJ41A	1: 0~5V RMS (Vg)* 3: 0~5V DC (Vz) 4: 0~20 mA (Iz) 5: 4~20 mA (Iy)** 8: 0~10V DC (Vd)	2: 12V 3: 15V 4: 24V	M: none	S3 SK	0.5	10V, 50V, 100V, 110V, 220V, 250V, 380V, 400V, 500V
CE-VJ31 CE-VJ41	3: 0~5V DC (Vz) 4: 0~20 mA (Iz) 5: 4~20 mA (Iy)** 6: 1~5V (Vy) 8: 0~10V DC (Vd)	8: 110V 9: 220V		SK SL		

* Tracking output (Vg) type not available in CE-VJ31A, CE-VJ41A and now the accuracy only 0.5.

** Loop resistance from 0 to 250Ω. Contact factory for loop resistance above 250Ω.

Part Number Example: CE-VJ41-32MS3-0.5/0-250V

Description: 3-phase 4-wire AC Voltage Transducer, Output: 0-5V, Power supply:+12V, no Window, Case style S3 , Accuracy: 0.5, Input: 0-250V.

Connections Diagram (see Chapter 4 for mounting dimensions)

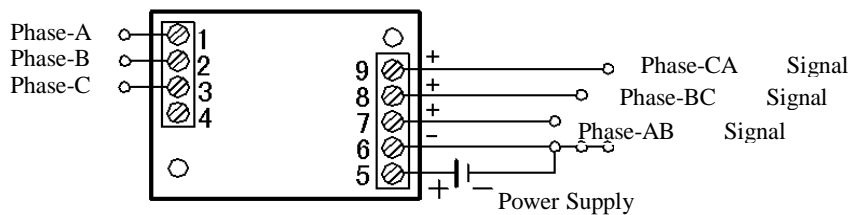

Fig. 3.2.5 CE-VJ31, CE-VJ31A Case style S3

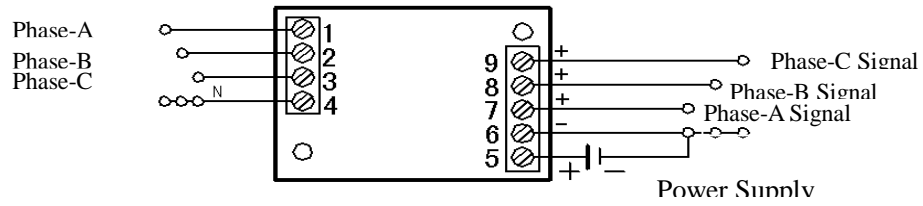

Fig.3.2.6 CE-VJ41, CE-VJ41A Case style S3

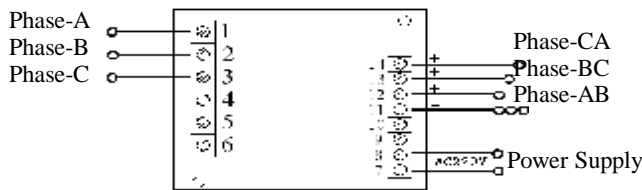

Fig. 3.2.7 CE-VJ31, CE-VJ31A Case style SK

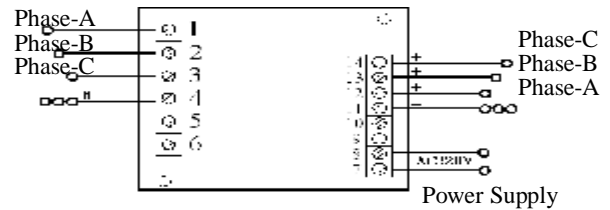

Fig.3.2.8 CE-VJ41, CE-VJ41A Case style SK

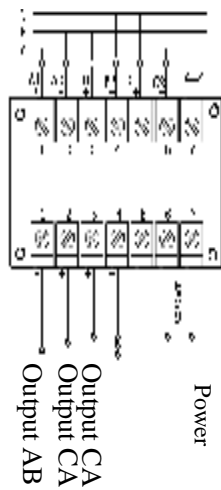

Fig.3.2.9 CE-VJ31, Case style SL

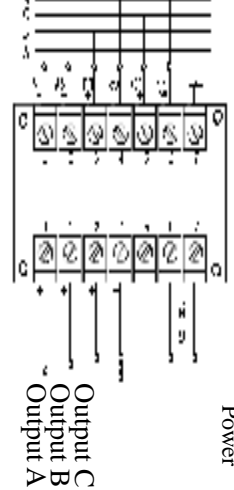

Fig.3.2.10 CE-VJ41, Case style SL

Typical Application:

1. Harmonic voltages
2. Chopped waveform drivers
3. Quickly varying voltage supplies
4. Phase fired controlled devices

Notice:

1. In case the input is 3-phase-3-wire system, the first output corresponds to the line voltage between V_{ab} , the second output corresponds to line voltage between V_{bc} , and the third output corresponds to line voltage between V_{ca} . In case the input is 3-phase-4-wire, three outputs correspond respectively to phase voltage of A, B and C phases.
2. The output signal and the Power supply must be grounded in common. Please keep right polarity connection, don't in error set.

3.2.3 1-phase DC Voltage Transducer

Specifications:

Series	Operating Principle	Isolation Voltage	Response Time	Overload Capacity	Power Consumption (mW)		Mounting
					Vz,Vd, Vg,Iz Output	Iy Output	
CE-VZ01	Linear Photoelectric Isolation Treble Isolation*	2500 VDC	≤15mS	2 Times 10 /sec	300	380	PCB / Din rail/ Screw
CE-VZ02	Electromagnetic Isolation				200	300	

* Treble Isolation: the input, output and power supply is isolated from each other.

Part Numbers:

Series	Output	Power Supply	Window (mm)	Case Style	Accuracy (%)	Rated Input
CE-VZ01	3: 0~5V DC (Vz) 4: 0~20mA (Iz)* 5: 4~20mA (Iy)*	2: 12V 3: 15V 4: 24V	M: none	S1 S2	0.2	10mV, 50mV, 75mV, 1V, 5V, 10V, 50V, 75V, 100V, 200V, 500V, 1000V
CE-VZ02	6: 1~5V DC(Vy) 8: 0~10V DC(Vd) F: OC frequency I output	8: 110V 9: 220V		S3		
		2: 12V 3: 15V 4: 24V		S1 S2		
					H2	

* Loop resistance from 0 to 250Ω. Contact factory for loop resistance above 250Ω.

Part Number Example: CE-VZ02-52MS1-0.2/0-75mV

Description: 1-phase DC Transducer, Output: 4-20mA, Power supply: +12V, No window, Case Style: S1, Accuracy: 0.2, Input Voltage: 0-75mV.

Connections Diagram (see Chapter 4 for mounting dimensions)

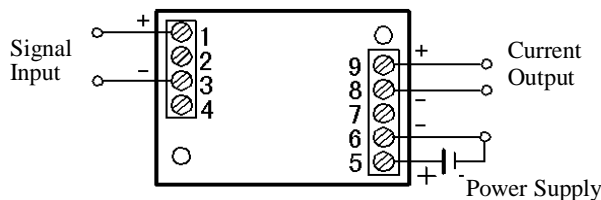

Fig. 3.2.11 CE-VZ01
Current output, Case style S

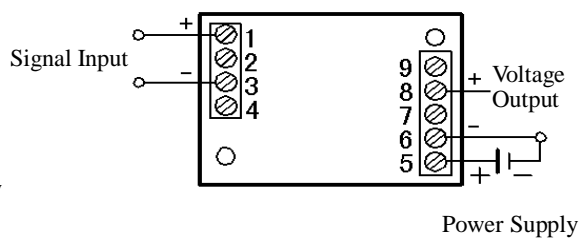

Fig. 3.2.12 CE-VZ02
Voltage Output, Case style S

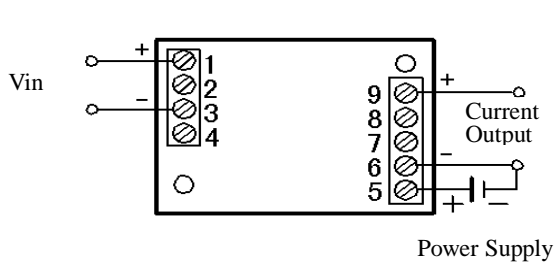

Fig. 3.2.13 CE-VZ02
Current Output, Case style S

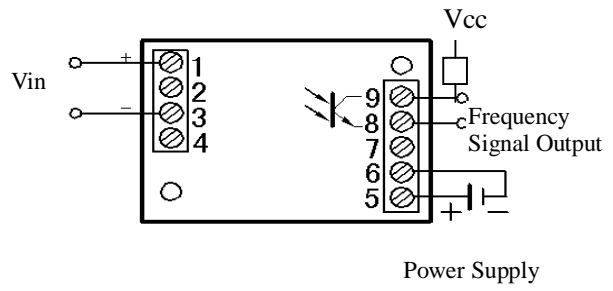

Fig.3.2.14 CE-VZ01, CE-VZ02
Frequency Output

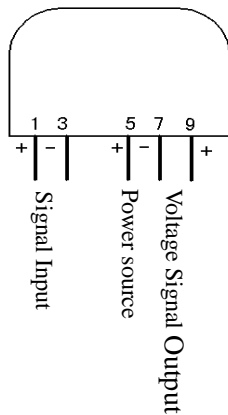

Fig. 3.2.15 CE-VZ02
Voltage Output, Case style H2,

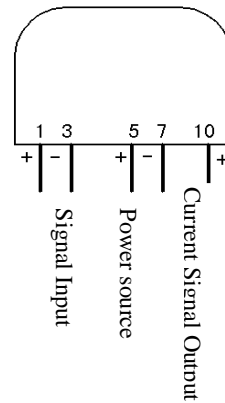

Fig. 3.2.16 CE-VZ02
Current Output, Case style H2,

Typical Application:

1. Mobile applications
2. Power Supply over/under sensing
3. Power sensing
4. Battery chargers and systems

Notice:

1. In case the input signal is bi-directional DC or pulsed DC, please give clear indication in your order.
2. Since CE-VZ01 is provided with treble isolations, the output signal and Power supply may not be grounded in common. (While that of other series must be grounded in common.)

3.3 Frequency Transducer

Specifications:

Series	Operating Principle	Isolation Voltage	Response Time	Overload Capacity	Power Consumption (mW)		Mounting
					Vz, Vd, Vg, Iz Output	Iy Output	
CE-F01 CE-F03	Photoelectric Isolation	2500V DC	200~600mS	2 Times 10/sec	480	600	PCB/ Din rail/ Screw

Part Numbers:

Series	Output	Power Supply	Input Waveform	Case Style	Accuracy (%)	Rated Input	
						Frequency	Voltage
CE-F01	3: 0~5VDC (Vz) 4: 0~20mA (Iz)* 5: 4~20mA (Iy)* 8: 0~10VDC (Vd)	2: 12V 3: 15V 4: 24V 8: 110V 9: 220V	R: Arbitrary wave pass zero F: Square Wave. Z: Sine curve wave. O: OC frequency signal T: TTL electricity level	S2 S3	0.5	55Hz,	50V,
CE-F03						Z: Sine curve wave.	S1 S3

* Loop resistance from 0 to 250Ω. Contact factory for loop resistance above 250Ω.

Part Number Example: CE-F01-32FS3-0.5/0~55Hz (250V)

Description: Frequency Transducer, Square Wave Signal (250V), Output: 0~5V, Power supply: +12V, Case style: S3, Accuracy: 0.5, Input:0~55Hz.

Connections Diagram (see Chapter 4 for mounting dimensions)

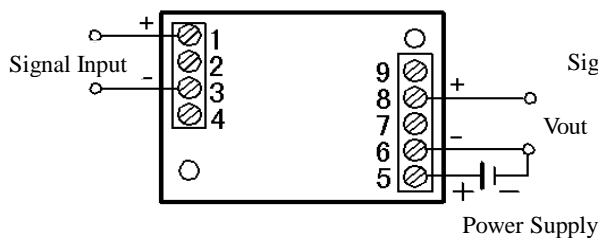

Fig 3.3.1 CE-F01
Voltage Output, Case style S

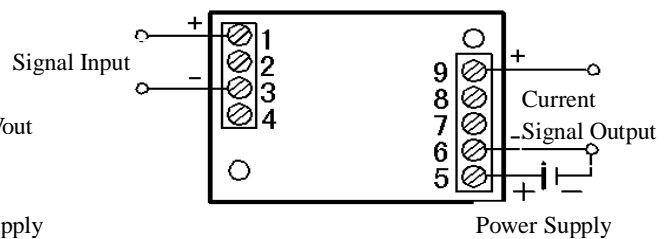

Fig. 3.3.2 CE-F01
Current Output, Case style S,

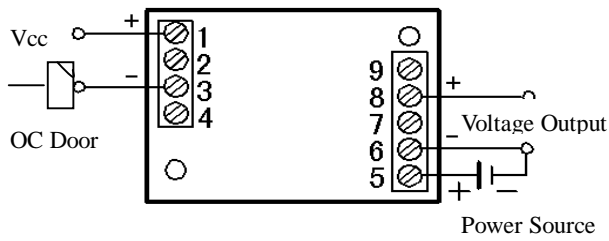

Fig. 3.3.3 CE-F01

OC Frequency Input, Voltage Output

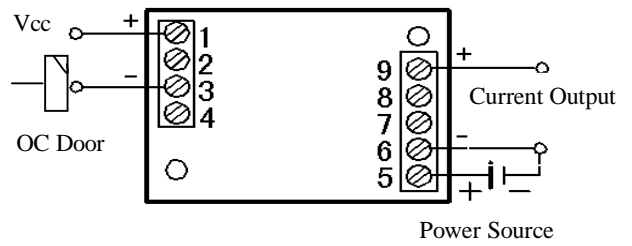

Fig. 3.3.4 CE-F01

OC Frequency Input, Current Output

Typical Application:

1. Power quality monitoring
2. Applications monitor generator sets
3. Multi-frequency control and monitoring
4. Inverter drives and systems

Notice:

1. Response of amplitude of frequency signal must not be lower than 20% of rated voltage.
2. There is no polarity requirement for the input signal connection. The responsive amplitude of frequency signal must not be lower than 20% of rated voltage.
3. The output signal and the Power supply must be grounded in common. Please keep right polarity connection of output.

3.4 Power Transducer:

Specifications

Series	Operating Principle	Isolation Voltage	Response Time	Overload Capacity	Power Consumption (mW)		Mounting
					Vz, Vd, Vg, Iz Output	Iy Output	
CE-P02 CE-Q02	Electro-magnetic Isolation	2500V DC	$\leq 700\text{mS}$	Current: 20Times 5/sec Voltage: 2 Times 10/sec	600	750	Screw/ Din rail
CE-P31 CE-Q31 CE-P41 CE-Q41					1000	1400	

Part Numbers

Series	Output	Power Supply	Window (mm)	Case Style	Accuracy %	Rated Input	
						Voltage	Current
CE-P02 CE-Q02	3: 0~5V DC (Vz) 4: 0~20mA (Iz)*	2: 12V 3: 15V 4: 24V 8: 110V 9: 220V	E: $\Phi 20$	SK	0.5	75V, 110V, 220V, 250V, 380V, 400V, 500V.	5A-300A
CE-P02 CE-Q02 CE-P31 CE-Q31 CE-P41 CE-Q41	5: 4~20mA (Iy)*	2: 12V 3: 15V 4: 24V 8: 110V 9: 220V	B: $\Phi 6.5$	S3 SK			5A, 10A, 15A, 20A, 25A.

* Loop resistance from 0 to 250Ω. Contact factory for loop resistance above 250Ω.

Part Number Example: CE-P41-52BS3-0.5/0~250V*0~5A

Description: 3-phase 4-wire Active Power Transducer, Output: 4~20mA, Power supply: +12V, Window: $\Phi 6.5$, Accuracy: 0.5, Case style: S3, Input Voltage: 0~250V, Current: 0~5A,

Connections Diagram (see Chapter 4 for mounting dimensions)

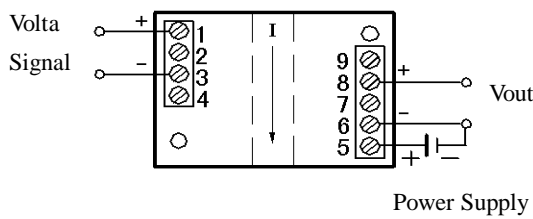

Fig. 3.4.1 CE-P02, CE-Q02
Voltage Output, Case style S

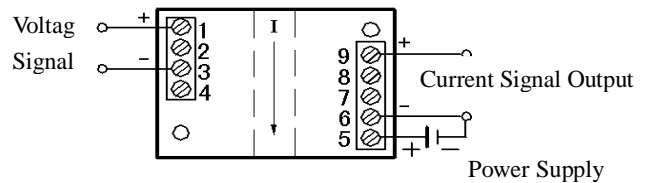

Fig. 3.4.2 CE-P02, CE-Q02
Current Output, Case style S

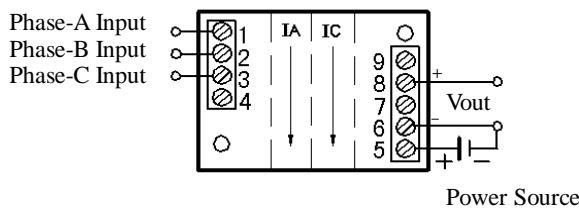

Fig. 3.4.3 CE-P31, CE-Q31
Voltage Output, Case style S

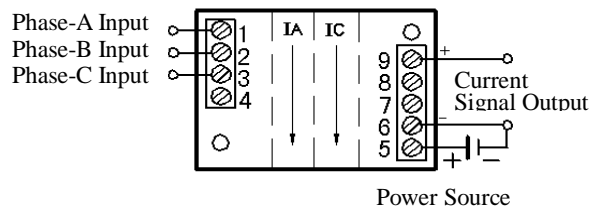

Fig. 3.4.4 CE-P31, CE-Q31
Current Output, Case style S,

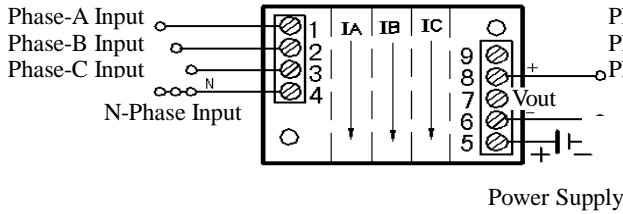

Fig. 3.4.5 CE-P41, CE-Q41
Voltage Output, Case style S

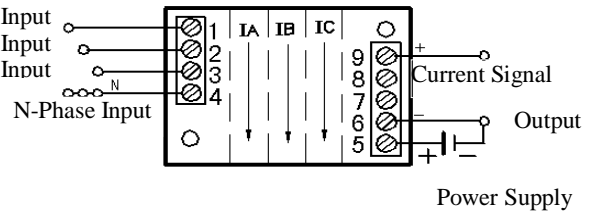

Fig. 3.4.6 CE-P41, CE-Q41
Current Output, Case style S

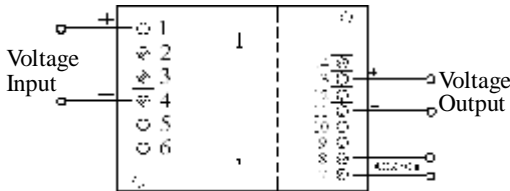

Fig. 3.4.7 CE-P02, CE-Q02
Voltage Output, Case style SK



Fig. 3.4.8 CE-P02, CE-Q02
Current Output, Case style SK

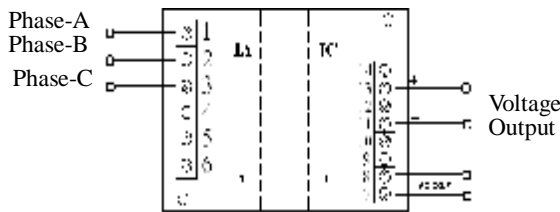

Fig. 3.4.9 CE-P31, CE-Q31
Voltage Output, Case style SK

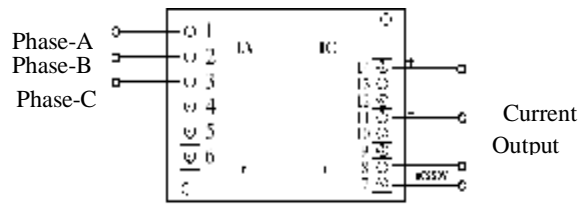

Fig. 3.4.10 CE-P31, CE-Q31
Current Output, Case style SK

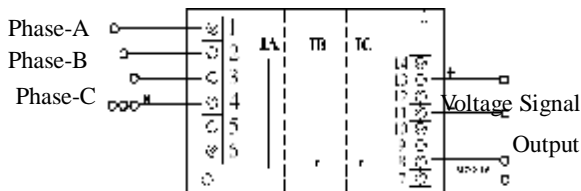

Fig. 3.4.11 CE-P41, CE-Q41
Voltage Output, Case style SK



Fig. 3.4.12 CE-P41, CE-Q41
Current Output, Case style SK

Typical Application:

1. Motor Efficiency
2. Multi-point power sensing
3. Energy Management
4. Remote power sensing over long distances

Notice:

1. The input current must pass through the window in the direction shown in Reference Diagram of Connections.
2. The output signal of 3-phase power transducer corresponds to total power of three phases.
3. In case the current to be measured is larger than 25A, it would be advisable to add AC current mutual inductor (CT) to each phase and take the secondary signal as input signal.

3.5 1-element AC/DC Offside Alarm Transducer

Specifications:

Series	Operating Principle	Isolation Voltage	Input Frequency Range	Response Time	Overload Capacity	Power Consumption (mW) **	Mounting
CE-VJ03-J	Electromagnetic Isolation	2500VDC	25~3kHz	<200mS	Current: 20 Times 5/sec at 500A, Voltage: 2Times, 10/sec. Relay Contact Current: ≤2A DC/AC	<600	Screw/ Din Rail
CE-VZ01-J	Treble Isolation*		DC	<50 mS			
CE-IJ03-J	Electromagnetic Isolation		25~3kHz	<200 mS			

* Treble Isolation: the input, output and power supply is isolated from each other.

** Static Power with Power supply 24V

Part Numbers:

Series	Output	Power Supply (DC)	Window	Case Style	Accuracy %	Threshold Value Input	Return Difference Input
						Voltage / current	%
CE-VJ03-J	Relay contacts	4:24V	M	S3	2.0	10V, 50V, 100V, 250V, 500V, 1000V	-5,-10, -20, -30
CE-VZ01-J						10mV, 75mV, 100mV, 1V, 5V, 10V, 50V, 100V, 250V, 500V, 1000V	
CE-IJ03-J			B: Φ6.5 E: Φ20			1A, 10A, 30A, 50A, 75A, 100A, 150A, 200A, 250A, 300A	

Part Number Example: CE-IJ03-J4ES3-2.0/75A-20

Description: AC Current Offside Alarm Transducer, Relay contacts Output, Power supply: 24V, Aperture: Φ13mm, Case style: S3, Accuracy: 2.0, Threshold Value: 75A, Return Input: -20%

Connections Diagram (see Chapter 4 for mounting dimensions)

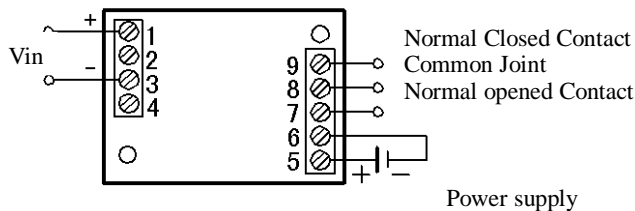

Fig 3.5.1 CE-VJ03-J、CE-VZ02-J
Case style S3

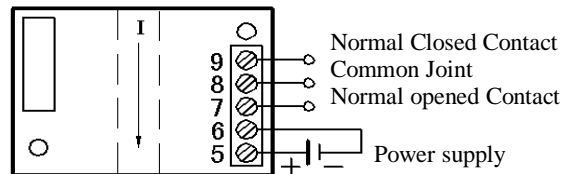

Fig. 3.5.2 CE-IJ03-J
Case style S3

Typical Application:

1. Load monitoring of DC power supply system
2. Safety Protect for safety system of various electric control equipments.

Notice:

1. The load current of output should not exceed the maximal current value, which relay contacts allow to pass.
2. 24V Power supply should be stabilized within ±5%.
3. We can set threshold value and return value as per your request if the above value can't meet your demand.

3.6 Standard Signal Isolator

Specifications:

Part Number	Rin	Isolator Voltage	Linearity Error	Rated Output	Power Consumption (mW)	Load	Response Time	Overload Capacity	Mounting
CE-IZ07-34	250 Ω	2500VDC	≤0.5%	0~5V	50	Voltage output: ≤3mA Current output: ≤300 Ω	≤150mS	2 times of rate input, 10times /sec	Din rail/ Screw
CE-IZ07-54				4~20mA	500				
CE-IZ07-64				1~5V	50				
CE-IZ27-34				0~5V (2 channel)	100				
CE-IZ27-54				4-20mA (2 channel)	100				
CE-IZ27-64				1~5V (2 channel)	100				
CE-IZ27-T4				Current & voltage (2 channel)	550				

Part Numbers:

Series	Output	Power Supply	Window	Case Style	Accuracy	Rated Input
CE-IZ07	3: 0~5V DC (Vz) 5: 4~20 mA (Iy)** 6: 1~5V (Vy)	4: +24V	M: none	S3	0.2 0.5	4~20mA
CE-IZ27 (2-channel output)	3: 0~5V DC (Vz) 5: 4~20 mA (Iy)** 6: 1~5V (Vy) T: Mixed output				0.5	

Part Number Example: CE-IZ07-54MS3-0.5/4-20mA

Description: 1-element standard signal isolator, Output: 4-20mA, Power supply: +24V, No aperture, Case style: S3, Accuracy: 0.5, Input current: 4-20mA

Connections Diagram (see Chapter 4 for mounting dimensions)

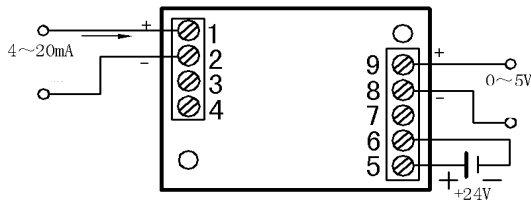

Fig. 3.6.1 CE-IZ07-34 with S case style

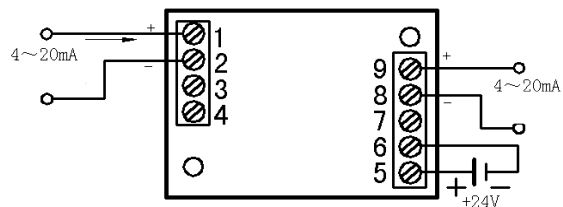

Fig. 3.6.2 CE-IZ07-54 with S case style

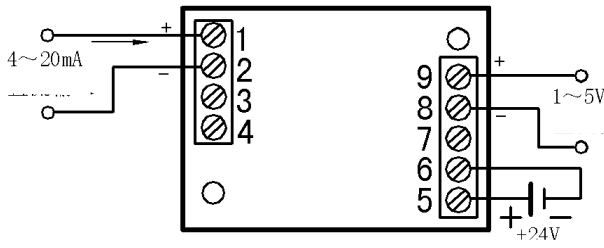

Fig. 3.6.3 CE-IZ07-64 with S case style

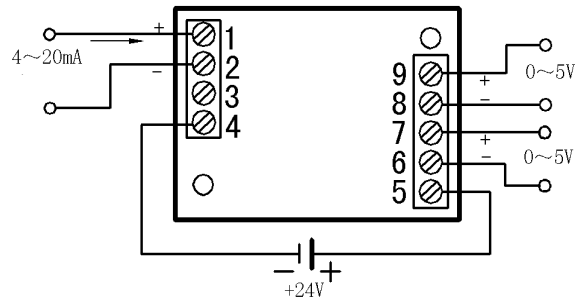

Fig.3.6.4 CE-IZ27-34 with S case style

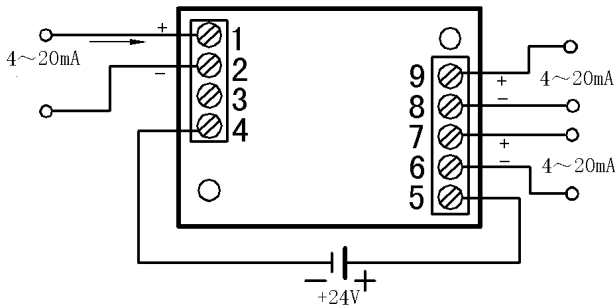

Fig.3.6.5 CE-IZ27-54 with S case style

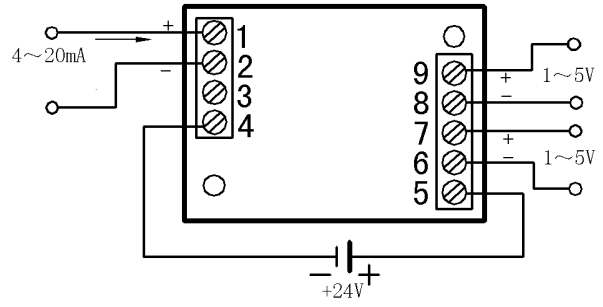

Fig. 3.6.6 CE-IZ27-64 with S case style

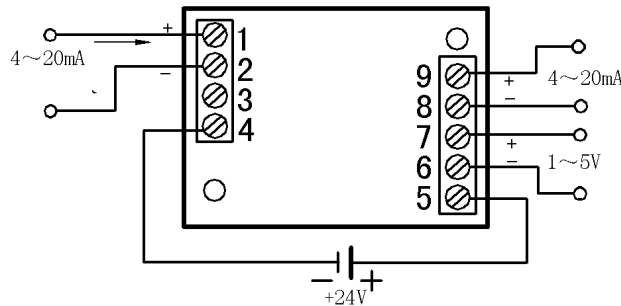

Fig.3.6.7 CE-IZ27-T4 with S case style

Application:

It can be used in the monitor system of oil, chemistry or energy distribution industry. And it will consummate the I/O function of the system.

Notice:

1. Please make sure to connect input, output and power supply correctly in accordance with the connection diagram of your part number before power on.
2. The standard signal isolators should be used only in environments without conductive dust, corrosive or explosive gases.
3. Please take additional and reasonable means for lightning protection, especially when the input and output wires of the standard signal isolator are exposed outdoor.

3.7 Self Power Transducer

3.7.1 self power current transducer

3.7.1.1 self power 1-element current transducer

Specifications:

Part Number	Output	Isolator Voltage	Linearity Error	Phase Deflection	Rated Output	Load	Response Time	Overload Capacity	Mounting
CE-IJ03-10	Vg	2500 VDC	≤0.2%	35'	0~1.5V	>1MΩ	≤15uS	20 times or <5/sec at 500A	Screw/ Din rail /PCB
CE-IJ03-20	Ig				2.5mA (input 5A)	≤1.5V			
					37.5mA (input 300A)	≤3.5V			
CE-IJ03-30	Vz*		≤1%	none	0~5V	>1MΩ	≤1S		
CE-IJ03-80	Vd**				0~10V				
CE-IJ03-J0	J***	On-off			400/5A (DC)				

* There are three input group can be chosen 2A/5A/10A, 20A/50A/75A and 100A/150A/200A. And in each group, the jumper can fix the input range of the three.

** There are two input group can be chosen 20A/50A/75A and 100A/150A/200. And the And in each group, the jumper can fix the input range of the three.

*** It can connect with AC/DC current/voltage load directly.

Part Numbers:

Series	Output	Power Supply	Window (mm)	Case Style	Accuracy	Rated Input
CE-IJ03	1: tracking voltage(Vg) 2: tracking current(Ig)	0: none	M: none	S2	1.0	1A, 2A, 5A
			B: φ 6.5			1A, 2A, 5A, 10A, 15A, 25A
	3:0~5VDC (Vz*) 8:0~10VDC(Vd**) J: relay output***		E: φ 20	S3		2A, 5A, 10A, 20A, 50A, 70A, 100A, 150A, 200A

Part Number Example: CE-IJ03-10BS2-1.0/0-10A

Description: 1-element AC current transducer, Output: tracking voltage0-1V, No power supply, Window: Φ6.5mm, Case style: S2, Accuracy: 1.0, Input current: 0-10A

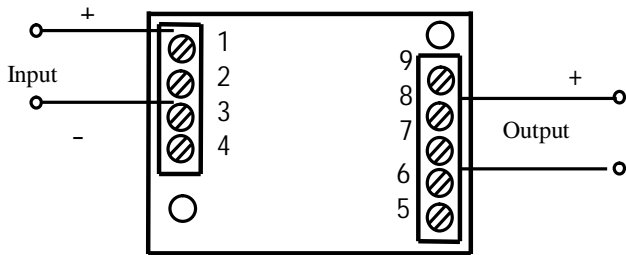

Fig.3.8.1 CE-IJ03 with terminal input

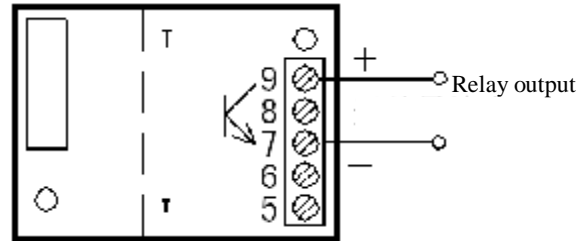

Fig. 3.8.2 CE-IJ03 with relay output

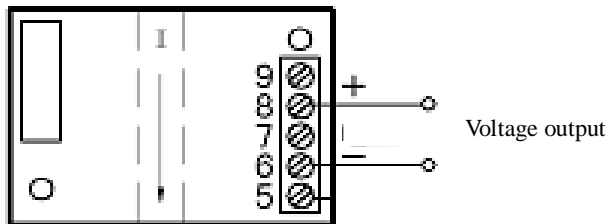

Fig. 3.8.3 CE-IJ03-x0 with voltage output

Application

1. Monitor the AC current of the motor.
2. Measure/monitor the second side of the CT.

Notice:

1. “+” which signed in the picture means the same polarity.
2. The size of window must be fit for the conducting wire to pass through. And the terminal input also could be chosen while the input current $\leq 5A$.
3. If there is a meter is used to test the output of the transducer, please make sure the accuracy of the meter is higher than the transducer.

3.7.1.2 self power 3-phase current transducer

Specifications:

Part number	Output	Isolation Voltage	Linearity Error	Phase Deflection	Rated Output	Load	Response Time	Overload Capacity	Mounting
CE-IJ31-10	Vg	2500VDC	≤0.2%	35'	0~1.5V	>1MΩ	≤15uS	20 times or <5/sec at 500A	Din rail/ Screw
CE-IJ31-20	Ig				2.5mA (input 5A)	≤1.5V			

Part Numbers:

Series	Output	Power Supply	Window (mm)	Case Style	Accuracy	Rated Input
CE-IJ31	1:tracking voltage (Vg) 2:tracking current (Ig)	0: none	B: φ 6.5	S3	0.5 1.0	1A, 2A, 5A, 10A, 15A, 25A

Part Number Example: CE-IJ31-10BS3-1.0/0-5A

Description: 3-elements AC current transducer, Output: tracking voltage 0-1.2V, No power supply, Aperture: Φ6.5mm, Case style: S3, Accuracy: 1.0, Input current: 0-5A

Connections Diagram (see Chapter 4 for mounting dimensions)

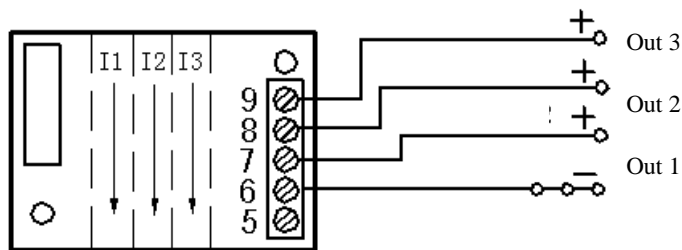

Diagram3.8.4 CE-IJ31 with S case style

Application

1. To monitor 3-phase motor
2. To monitor the secondary side of the CT

Notice:

1. “+” which signed in the picture means the same polarity.
2. The size of window must be fit for the conducting wire to pass through.
3. If there is a meter is used to test the output of the transducer, please make sure the accuracy of the meter is higher than the transducer.

3.7.2 self power voltage transducer

3.7.2.1 self power 1-phase voltage transducer

Specifications:

Part Number	Output	Isolation Voltage	Linearity Error	Phase Deflection	Rated Output	Load	Response Time	Overload Capacity	Mounting
CE-VJ03-10	V _g	2500 VDC	≤0.2%	35'	0~1V	>1MΩ	≤15uS	2 times <5/sec	Din rail / PCB/ Screw
CE-VJ03-20	I _g				0~1mA	≤1V			

Part Numbers:

Series	Output	Power Supply	Window (mm)	Case Style	Accuracy	Rated Input
CE-VJ03	1:tracking voltage (V _g) 2:tracking current (I _g)	0: one	M: none	S2	0.5 1.0	10V, 50V, 100V, 110V 220V, 250V, 380V 400V, 500V, 600V

Part Number Example: CE-VJ03-20MS2-1.0/0-400V

Description: 1-phase AC voltage transducer, Output: tracking current 0-1mA, No power supply, No aperture, Case style: S2, Accuracy: 1.0, Input current:0- 400V.

Connections Diagram (see Chapter 4 for mounting dimensions)

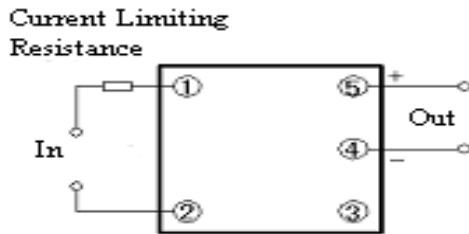

Fig. 3.8.5 CE-VJ03 (H1 case style)

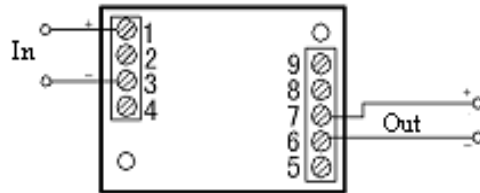

Fig. 3.8.6 CE-VJ03 (S case style)

Application:

1. Monitor the voltage of the motors
2. Monitor the secondary side of the VT

Notice:

1. “+” which signed in the picture means the same polarity.
2. The input voltage should not be over the rated voltage. The H1 must be used with corresponding current limiting resistance.
3. If there is a meter is used to test the output of the transducer, please make sure the accuracy of the meter is higher than the transducer.

3.7.2.2 self power 3-phase voltage transducer

Specifications:

Part number	Output	Isolator Voltage	Linearity Error	Phase Deflection	Rated Output	Load	Response Time	Overload Capacity	Mounting
CE-VJ41-10	Vg	2500 VDC	≤0.2%	35'	0~1V	>1MΩ	≤15uS	2 times <5/sec	Din rail /Screw
CE-VJ41-20	Ig				0~1mA	≤1V			

Part Numbers:

Series	Output	Power Supply	Window (mm)	Case Style	Accuracy	Rated Input
CE-VJ41	1:tracking voltage (Vg) 2:tracking current (Ig)	0: none	M: none	S3	0.5 1.0	10V, 50V, 100V, 110V, 220V, 250V 380V, 400V, 600V

Part Number Example: CE-VJ41-10MS3-0.5/0-380V

Description: 3-phase 4-wire AC voltage transducer, Output: tracking voltage 0-1.2V, No power supply, No aperture, Case style: S3, Accuracy: 0.5, Input current: 0-380V.

Connections Diagram (see Chapter 4 for mounting dimensions)

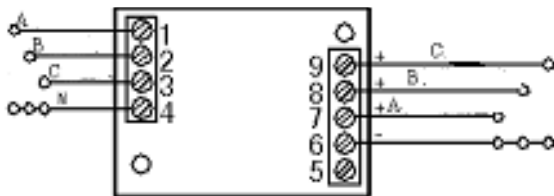

Fig. 3.8.7 CE-VJ41 (S case style)

Application:

1. Monitor the voltage of the motors
2. Monitor the secondary side of the VT

Notice:

1. “+” which signed in the picture means the same polarity.
2. The input voltage should not be over the rated voltage.
3. If there is a meter is used to test the output of the transducer, please make sure the accuracy of the meter is higher than the transducer

3.8 Split Core Self Power AC Current Transducer

Specifications:

Part Number	Output	Isolation Voltage	Linearity Error	Load	Response Time	Overload Capacity	Mounting
CE-IJ03-30 CE-IJ03-80	3: 0~5V (Vz) 8: 0~10V(Vd)	2500 VDC	≤1%	>3MΩ	1S	20 times or <5/sec at 500A	Din rail/ Screw

Part Numbers:

Series	Output	Power Supply	Window (mm)	Case Style	Accuracy	Rated Input
CE-IJ03	3: 0~5VDC (Vz*) 8: 0~10VDC(Vd**)	0: none	G: φ 31	S4	1.0	20A, 50A, 75A 100A, 150A, 200A

* There are two input group can be chosen 20A/50A/75A and 100A/150A/200A. And in each group, the jumper can fix the input range of the three.

** There are two input group can be chosen 20A/50A/75A and 100A/150A/200A. And in each group, the jumper can fix the input range of the three.

Part Number Example: CE-IJ03-30GS4-1.0/0-50A

Description: Split core 1-element AC current transducer, Output:0-5V, No power supply, Aperture: Φ31mm, Case style: S4, Accuracy: 1.0, Input current:0- 50A.

Connections Diagram (see Chapter 4 for mounting dimensions)

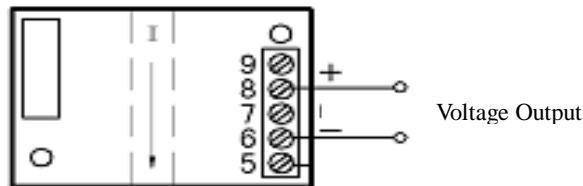

Fig. 3.9.1CE-IJ03-x0GS4 with voltage output

Application:

1. Multi-point current sensing and control panels
2. Monitor motor faults
3. Monitor heating elements
4. Monitor lighting elements

Notice:

1. If you want to open/close the split core, press and move the orange bolt to the open/close direction.
2. The conductor carrying the input current should pass through the center of the aperture as perpendicularly as possible. And lock the bolt.
3. If there is a meter is used to test the output of the transducer, please make sure the accuracy of the meter is higher than the transducer

3.9 Split Core DC Current Transducer

Specifications:

Series	Operating Principle	Isolation Voltage	Response Time	Overload Capacity	Power Consumption (mW)		Mounting
					Vz, Vd, Vg, Iz Output	Iy Output	
CE-IZ04	Hall effect	2500VDC	≤200mS	20 times or <5/secat 500A	550	600	Din rail /Screw

Part Numbers:

Series	Output	Power Supply	Window (mm)	Case Style	Accuracy	Rated Input
CE-IZ04	3: 0~5VDC (Vz) 4: 0~20mA (Iz) 5: 4~20mA (Iy) 8: 0~10V DC (Vd)	4: 24V	G: φ 31	S4	1.0	30A, 50A, 80A, 100A, 120A, 150A, 200A, 300A

Part Number Example: CE-IZ04-34GS4-1.0/0-50A

Description: Split core 1-element DC current transducer, Output:0-5V, Power supply+24V, Aperture: φ31mm, Case style: S4, Accuracy: 1.0, Input current: 0-50A.

Connections Diagram (see Chapter 4 for mounting dimensions)

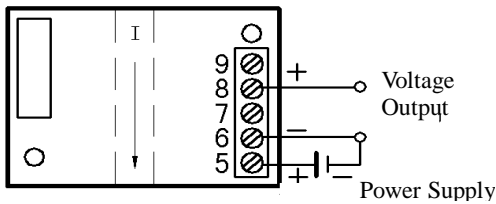

Fig. 3.10.1 IZ04-xxGS4 with voltage output

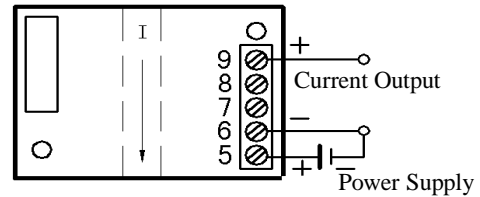

Fig.3.10.2 IZ04-xxGS4 with current output

Application:

1. Directly connect to PLC
2. Sense motor stalls and short circuits
3. Industrial instrumentation
4. Process control loops
5. Phase Fired Controlled Heaters

Notice:

1. If you want to open/close the split core, press and move the orange bolt to the open/close direction.
2. The conductor carrying the input current should pass through the center of the aperture as perpendicularly as possible. And lock the bolt.
3. If the input is bi-directional signal, please mark it in your order.
4. Apply power to the transducers only after check out the input signal, Power supply, and connection diagram.

3.10 Split Core AC Current Transducer

Specifications:

Series	Operating Principle	Isolation Voltage	Response Time	Overload Capacity	Power Consumption (mW)		Mounting
					Vz, Vd, Vg, Iz Output	Iy Output	
CE-IJ03-xxGS4 CE-IJ03A-xxGS4	Electro-magnetic induction	2500VDC	≤250ms	20 times or <5/sec at 500A	360	450	Din rail /Screw

Part Numbers:

Series	Output	Power Supply	Window(mm)	Case Style	Accuracy %	Rated Input
CE-IJ03 CE-IJ03A	3: 0~5VDC (Vz) 4: 0~20mA (Iz)* 5: 4~20mA (Iy)* 8: 0~10VDC (Vd)**	2: 12V 3: 15V 4: 24V	G: Φ31	S4	1.0	5A, 10A, 15A, 25A, 30A, 50A, 75A, 100A, 120A, 150A, 200A, 250A, 300A

* For output Iz and Iy, load would be less than 250 Ω . Contact us for above 250 Ω < RL ≤ 500 Ω .

** Output Id not available in CE-IJ03A.

Part Number Example: CE-IJ03-32GS4-1.0/50A

Description: Split core single-phase AC current transducer, Output: 0-5V, Power supply +12V,

Aperture: Φ31mm, Case style: S4, Accuracy: 1.0, Input current: 0- 50A.

Connections Diagram

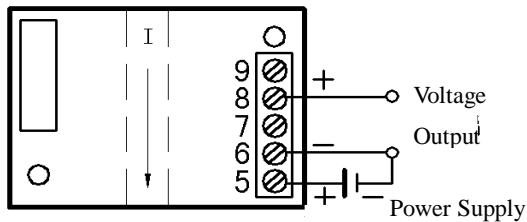

Fig.3.11.1 CE-IJ03-xxGS4 with voltage output

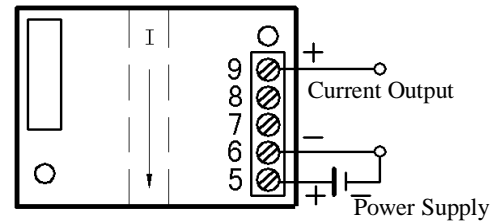

Fig. 3.11.2 CE-IJ03-xxGS4 with current output

Application:

1. Directly connect to PLC
2. Sense motor stalls and short circuits
3. Industrial instrumentation
4. Process control loops

Notice:

1. If you want to open/close the split core, press and move the orange bolt to the open/close direction.
2. The conductor carrying the input current should pass through the center of the aperture as perpendicularly as possible. And lock the bolt.
3. Make sure the polarities are in right connection. The output and the power supply must be common grounded.
4. If there is a meter used to test the output of the transducer, please make sure the accuracy of the meter is higher than the transducer.

3.11 Power Supply

Power supply and dimensions (mm) : CE-WYS-1, CE-WYS-2

CE-WYS-1

Model	CE-WYS-1/1A/1B
Input Voltage	220V±10%, 50Hz
Rated Current Output	500mA
Output Voltage	DC ±12V, ±15V, +24V
Output Ripple	≤10mV

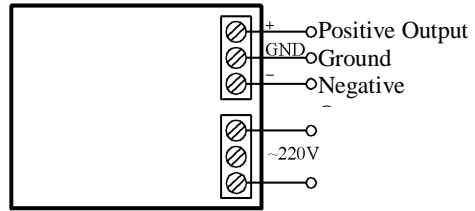
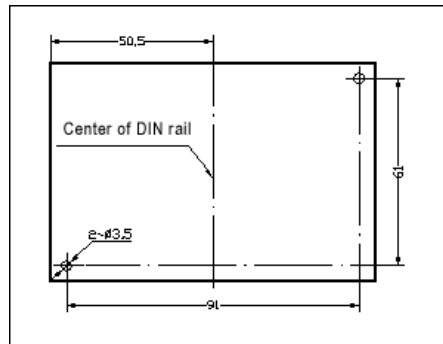

Fig.5.1.1 Connections for



Unit: mm

CE-WYS-2

Model	CE-WYS-2
Input Voltage	220V±10%, 50Hz
Rated Current Output	200mA
Output Voltage	DC +12V, +15V, +24V

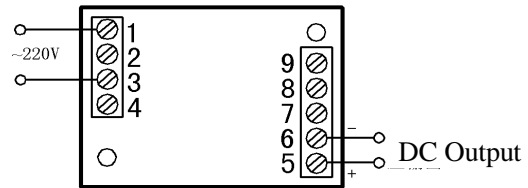
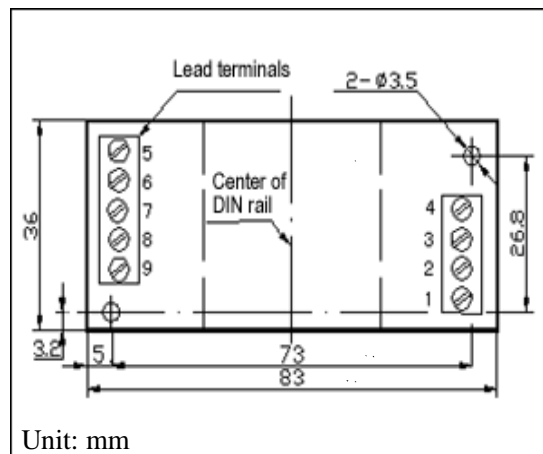

Fig. 5.1.2 Connections of CE-WYS-2



Unit: mm

Note: CE-WYS-1 and CE-WYS-2 are switching mode regulated power supply with positive voltage output. The voltage output of CE-WYS-1A is not adjustable. The voltage output of CE-WYS-1B linear regulated power supply is adjustable. CE-WYS-2 is of S3 case style.

Chapter 4 Case style and Mounting Diagram

4.1 Case Styles and Outline Dimension



S1



S2

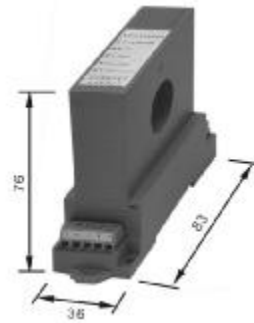

S3

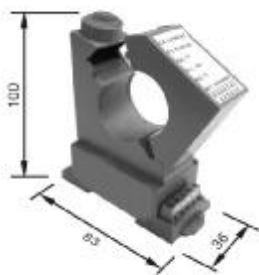

S4



H1

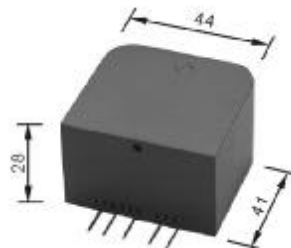

H2

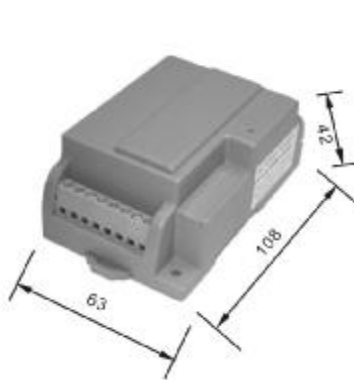

SK1



SK2



SK3



SL

4.2 Mounting Dimensions (mm)

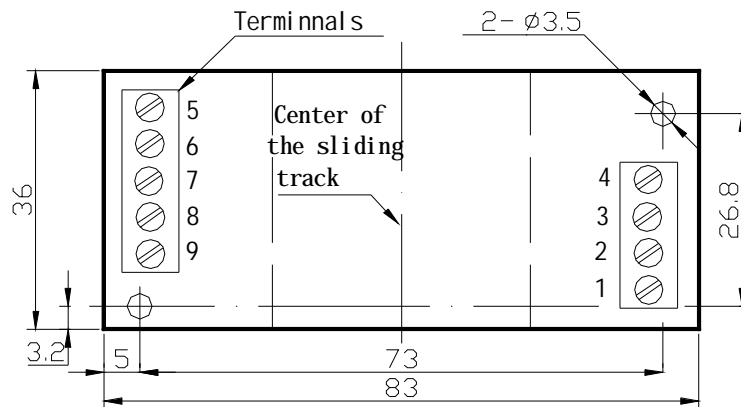

For Case style S1, S2 , S3 and S4

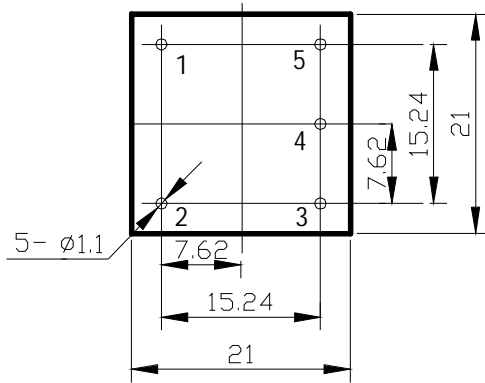

For Case style H1 (Top view)

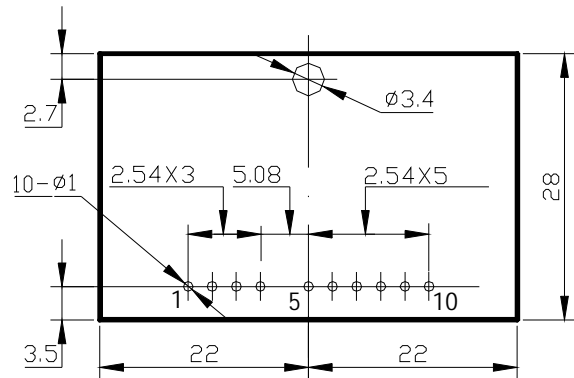

For Case style H2 (Top view)

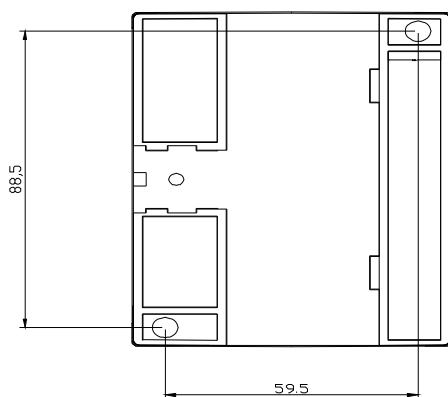

For Case style SL(Top view)

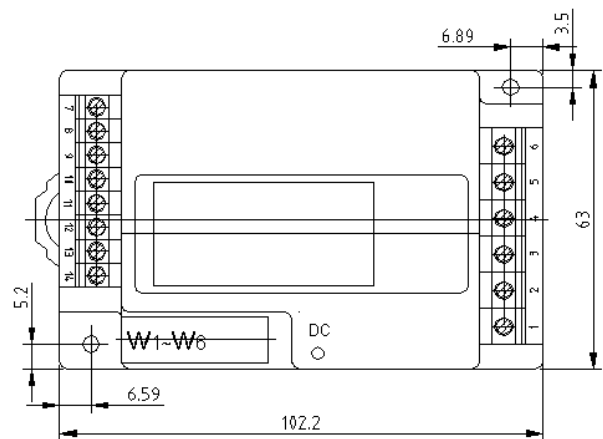

For Case style SK(Top view)

Chapter 5 Notes for Ordering

5.1 Ordering Instructions

1. Ensure a complete correct part number and product descriptions are used according to instructions in Chapter 1. The ordering information must include the complete description including input and output parameters such as rated value, output functions, Power supply and case style etc. Included with your order must be quantity, delivery and shipping requirements. Provide complete company name, address, fax number, and email address. Be sure to provide the name of the contact person that we can contact with any questions.
2. The complete order must be signed by both the seller and buyer.
3. Payment is by irrevocably L/C at sight for large quantities or 50% in advance and the remaining to be paid before shipment for small quantity.

5.2 Installation Notes

1. Verify the part number and description are correct according to the packing list and product labels.
2. Apply power to the transducers only after a thorough checking of the input signal, Power supply according to connections diagram.
3. The Power supply voltage must be within $\pm 2\%$ with noise less than 0.4%. V_{pp}
4. The transducers with current output may only be used with load resistance of less than 250 Ω . The voltage output transducers must be connected to a load of greater than 2K Ω
5. The transducers should only be used in environments having no static electricity, excessive dust, corrosive or explosive gases.
6. Please ensure the terminal screws are tightened securely and reliably before the electrical testing with a multi-meter directly on the terminals
7. Calibration of the units with equipment that has accuracy ratings greater than the rating of the transducers. Ensure that the equipment and transducers have been operating for a minimum of 15 minutes before calibration.
8. The transducers should not be used in environments with strong electromagnetic interference. Standard precautions such as shielding the input and/or output lines should be observed. All lines should be kept as short as possible. If a group of transducers are mounted together, keep a space more than 10 mm between adjacent units. A 35mm (width) track is to be used for DIN rail mounting with $\Phi 3$ screw for PCB surface mounting.
9. The transducers have been calibrated before delivery. Please contact the company if readjustments are required.
10. Do not remove or destroy the product labels.

5.3 Warranty service

1. SHENZHEN SENSOR ELECTRONIC TECHNOLOGY CO., LTD. guarantees the original purchaser of our products a 24-month warranty from date of purchase. Repairs or other modifications made by unauthorized persons to the transducer will make all warranties, express or implied, null and void. Warranty does not include any component replacement if damages caused by improper use.



S1



S2



S3



S4



H1



SL



MSK



ESK



BSK