

Hall Effect DC Current Transducer



Shenzhen Sensor Electronic
Technology Co.,Ltd

CE-IZ04-95B2-1.0

Output: 0-4V; Power supply: $\pm 12V$;

Window: 64*16mm; Case Style:B2; Accuracy:1.0

Features

High isolation, small size, light in weight, less power consumption, window structure, no insertion loss

Specifications

Operating temperature: $-10\sim 80^{\circ}\text{C}$

Measuring range: $0\sim \pm 300\sim \pm 1800\text{A DC}$

Temperature drift: $0.05\% / ^{\circ}\text{C}$

Isolation : $3\text{KVRMS}/50\text{Hz}/1\text{Min}$

Current consumption: $\pm 18\text{mA}$

Response time: $7\mu\text{S}$

Overload: 20 times of the maximum value of measuring range

Case Style & Mounting Dimensions

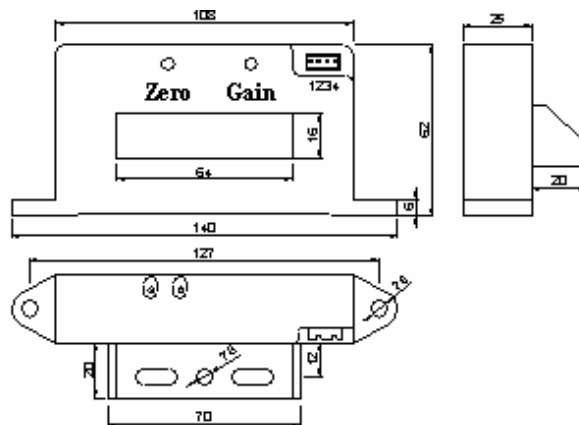

Connections Diagrams

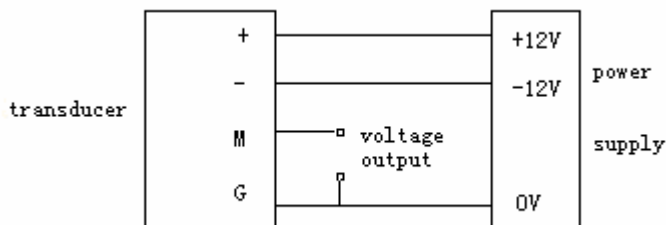

+: Positive power supply
-: Negative power supply
M: Signal output
G: Ground

Notice

- Connect the terminals of power supply, outputs respectively and correctly, never make wrong connection.
- Two potentiometers can be adjusted, only if necessary, by turning slowly to the required accuracy with a small screwdriver
- The best accuracy can be achieved when the window is fully filled with bus-bar(current carrying conductor)
- The in-phase output can be obtained when the direction of current of carrying conductor is the same as the direction of arrow marked on the transducer case.