

# Hall Effect DC Current Transducer



Shenzhen Sensor Electronic  
Technology Co.,Ltd

## CE-IZ04-35C11-1.0

Output: 0-5V; Power supply:  $\pm 12V$ ;

Window: 183\*70mm; Case Style: C11; Accuracy: 1.0

### Features

High isolation, small size, light in weight, less power consumption, window structure, no insertion loss

### Specifications

Operating temperature:  $-10\sim 80^{\circ}\text{C}$

Measuring range:  $0\sim \pm 4000\sim \pm 10000\text{A DC}$

Temperature drift:  $0.025\% /^{\circ}\text{C}$

Isolation : 3KVRMS/50Hz/1Min

Current consumption:  $\pm 25\text{mA}$

Response time: 15 $\mu\text{S}$

Overload: 20 times of the maximum value of measuring range

### Case Style & Mounting Dimensions



L\*W\*H: 252\*86\*166mm

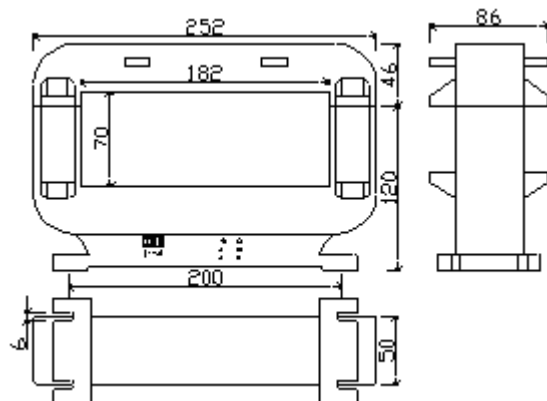

### Connections Diagrams

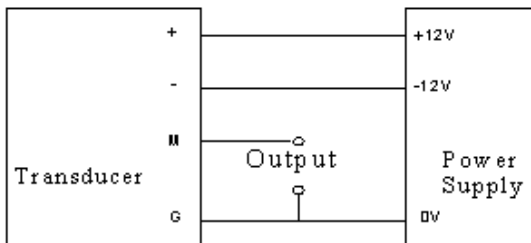

+: Positive power supply  
-: Negative power supply  
M: Signal output  
G: Ground

### Notice

- The best accuracy can be achieved when the window is fully filled with bus-bar(current carrying conductor)
- The in-phase output can be obtained when the direction of current of carrying conductor is the same as the direction of arrow marked on the transducer case.